

IntechOpen

Mesoporous Materials

Properties and Applications

Edited by Manjunath Krishnappa



Mesoporous Materials - Properties and Applications

Edited by Manjunath Krishnappa

Published in London, United Kingdom

Mesoporous Materials – Properties and Applications

<http://dx.doi.org/10.5772/intechopen.79068>

Edited by Manjunath Krishnappa

Contributors

Ratna Ediati, Pramita Elfianuari, Eko Santoso, Dety Oktavia Sulistiono, Muhammad Nadjib, Hendrik Oktendy Lintang, Leny Yuliati, Yanan Gao, Lifeng Deng, Junfeng Zhang, Ranganatha S, Mohamed Ali Ghanem, Abdullah M. Al-Mayouf, Mabrook S. Amer, James M gaya, Egid Mubofu

© The Editor(s) and the Author(s) 2019

The rights of the editor(s) and the author(s) have been asserted in accordance with the Copyright, Designs and Patents Act 1988. All rights to the book as a whole are reserved by INTECHOPEN LIMITED. The book as a whole (compilation) cannot be reproduced, distributed or used for commercial or non-commercial purposes without INTECHOPEN LIMITED's written permission. Enquiries concerning the use of the book should be directed to INTECHOPEN LIMITED rights and permissions department (permissions@intechopen.com).

Violations are liable to prosecution under the governing Copyright Law.



Individual chapters of this publication are distributed under the terms of the Creative Commons Attribution 3.0 Unported License which permits commercial use, distribution and reproduction of the individual chapters, provided the original author(s) and source publication are appropriately acknowledged. If so indicated, certain images may not be included under the Creative Commons license. In such cases users will need to obtain permission from the license holder to reproduce the material. More details and guidelines concerning content reuse and adaptation can be found at <http://www.intechopen.com/copyright-policy.html>.

Notice

Statements and opinions expressed in the chapters are these of the individual contributors and not necessarily those of the editors or publisher. No responsibility is accepted for the accuracy of information contained in the published chapters. The publisher assumes no responsibility for any damage or injury to persons or property arising out of the use of any materials, instructions, methods or ideas contained in the book.

First published in London, United Kingdom, 2019 by IntechOpen

IntechOpen is the global imprint of INTECHOPEN LIMITED, registered in England and Wales, registration number: 11086078, The Shard, 25th floor, 32 London Bridge Street

London, SE19SG – United Kingdom

Printed in Croatia

British Library Cataloguing-in-Publication Data

A catalogue record for this book is available from the British Library

Additional hard and PDF copies can be obtained from orders@intechopen.com

Mesoporous Materials – Properties and Applications

Edited by Manjunath Krishnappa

p. cm.

Print ISBN 978-1-83880-649-1

Online ISBN 978-1-83880-650-7

eBook (PDF) ISBN 978-1-83880-650-7

Meet the editor



Krishnappa Manjunath received his master's degree from Sri Venkateshwara University, Tirupathi, India. He received his PhD in Chemistry from Jain University, India, under the guidance of Prof. T. Ramakrishnappa in 2016. During his PhD, he was awarded a prestigious "CNPq-TWAS" fellowship in 2014 for a one-year internship and worked with Prof. Jairton Dupont, FRS, at the Laboratory of Molecular Catalysis, UFRGS, Brazil. In 2016, he joined the International Centre for Materials Science, JNCASR, Bangalore, where he is currently working as a research associate with Prof. C. N. R. Rao, FRS. His research interests mainly focus on investigations of aliovalent anion substitution in inorganic materials and their applications for water splitting reactions to generate hydrogen. He has authored more than 30 internationally reputed articles, mainly concerning advanced functional materials and nanomaterials for photocatalysis.

Contents

Preface	XIII
Section 1	
Synthesis and Properties of Mesoporous Materials	1
Chapter 1	3
Synthesis and Characterizations of Titanium Tungstosilicate and Tungstophosphate Mesoporous Materials <i>by Mohamed A. Ghanem, Abdullah M. Al-Mayouf and Mabrook S. Amer</i>	
Chapter 2	27
Mesoporous Materials Prepared Using Cashew Nut Shell Liquid and Castor Oil as Surfactants <i>by James Mgaya and Egid Mubofu</i>	
Section 2	
Mesoporous Materials and their Potential Applications	43
Chapter 3	45
Synthesis of MCM-41/ZIF-67 Composite for Enhanced Adsorptive Removal of Methyl Orange in Aqueous Solution <i>by Ratna Ediati, Pramita Elfianuar, Eko Santoso, Dety Oktavia Sulistiono and Muhammad Nadjib</i>	
Chapter 4	59
Synthesis, Properties, and Their Potential Application of Covalent Organic Frameworks (COFs) <i>by Lifeng Deng, Junfeng Zhang and Yanan Gao</i>	
Chapter 5	87
Designed Mesoporous Materials toward Multifunctional Organic Silica Nanocomposites <i>by Hendrik O. Lintang and Leny Yuliati</i>	
Chapter 6	105
Mesoporous Materials for High-Performance Electrochemical Supercapacitors <i>by Ranganatha Sudhakar</i>	

Designed Mesoporous Materials toward Multifunctional Organic Silica Nanocomposites

Hendrik O. Lintang and Leny Yuliati

Abstract

Functionalized mesoporous silica materials (MSMs) using grafting (post-synthesis) and one-pot (co-condensation) synthesis methods of organic functional groups (periodic mesoporous organosilicas, PMOs) have been developed for many emerging applications. To improve the functions, designed MSMs have received particular attention using an organic motif as a molecule of surfactants for the template synthesis with a silica source in the sol-gel reaction. The resulting mesoporous silica materials can provide characteristic multifunctional nanocomposites consisting of a monomer for synthesizing polymer in the silicate nanochannels. Moreover, the nanocomposites can be also synthesized using a self-assembled organic motif for organizing one-dimensional structure in the silicate nanochannels. The resulting hybrid nanomaterials have been mainly reported to provide fluorescent properties. However, the utilization of phosphorescent nanocomposites for specific applications has not yet reported so far. By utilizing a self-assembled metal complex (organometallic), this chapter particularly highlights recent achievements of designed mesoporous silica materials for the fabrication of advanced luminescent nanostructures with phosphorescent properties where the potential applications will be discussed in detail for self-repairing and thermally resistive materials, metal ions sensors, template synthesis nanoparticles, and catalysts. Such better and novel performance can be only achieved using a designed template for the sol-gel synthesis of mesoporous silica nanocomposites.

Keywords: hybrid material, luminescence, mesoporous silica, metal complex, nanocomposite, nanomaterial, one-pot synthesis, organosilica, surfactant, template

1. Introduction

Silica sources have been widely used for the preparation of solid containing pores (porous) materials. According to definition by International Union of Pure and Applied Chemistry (IUPAC) in 1972, porous materials can be defined based on the pore size (diameter). Materials with pore size less than 2 nm, between 2 to 50 nm and 50 to 7500 nm as well as above 7500 nm are classified as microporous, mesoporous, macroporous and megapore materials, respectively [1]. Such porous materials have been widely used for many applications due to their characteristics in pore size and surface area [2].

Japanese and American researchers have independently invented ordered Mesoporous Silica Materials (MSMs) in early 1990 using various kinds of surfactants

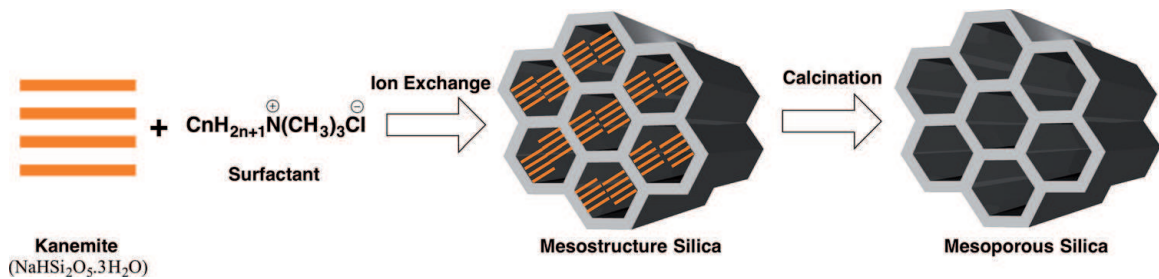

Figure 1.

Synthetic scheme for the formation of Folded Sheet Materials (FSM)–16 through calcination of as-synthesized mesostructure silica from the sol-reaction of kanemite as a silica source and cationic surfactant.

and silica sources. Based on the research by Japanese researchers, the first ordered MSMs have been discovered by using intercalation of cationic micelles in a layered silicate kanemite [3, 4]. These MSMs have a hexagonal array of uniform channels that is called as *Folded Sheet Materials (FSM)–16*. As shown in **Figure 1**, the FSM-16 was prepared from a condensation of three-dimensional silicate networks through sodium (alkali) cation exchange of kanemite with organic cations of alkyltrimethylammonium ions having chloride anion. On the other hands, American researchers from Mobil Research and Development Corporation [5, 6] have also discovered different ordered MSMs using cetyltrimethylammonium bromide (CTAB) as a surfactant for templating silica framework. The resulting MSMs have been classified as *Mobil Composition of Matters (MCM)–41* families consisting different geometry of MSMs such as hexagonal (MCM-41), cubic (MCM-48), and lamellar (MCM-50).

Liquid Crystal Templating (LCT) mechanism has been proposed for the formation of the MCMs with a hexagonal structure. In particular, surfactant in their liquid crystal properties (lyotropic) plays an important role for the formation of MCMs [5, 6]. **Figure 2** shows the self-assembly of surfactant in the presence of silica sources to form mesoporous silica. Typically, the surfactant such as CTAB self-assembles to form a micelle and then it will form a rod micelle. Such rod micelle at the certain concentration (*critical micelle concentration*, CMC) can self-assemble to form a structure with a hexagonal geometry. In the presence of organic template, the interaction can occur through oligomerization of silica source to hexagonal packing under acidic or basic condition. It will then produce mesostructure silica containing the surfactant molecules in the silicate nanochannels. By using calcination method, both groups have demonstrated that highly ordered and well-defined nanoscopic channels of mesostructures can be designed and then synthesized with good characteristics such as large surface areas, high thermal and mechanical stability, uniform channel distribution, and pore size modification.

Recent research in the development of ordered MSMs have been widely focused using different kinds of surfactants. For example, *Hexagonal Mesoporous Silica (HMS)* with slightly disordered hexagonal structure and thicker walls as well as superior thermal stability has been synthesized using neutral amine surfactants [7]. By using the same type of surfactant, *Michigan State University (MSU-1)* has been synthesized using neutral polyethylene oxide (PEO) surfactant [8]. Moreover, *Santa Barbara Amorphous (SBA)-15* has been invented with good characteristic such as large pore size and well tunable in the range of 5–30 nm, thicker pore walls, and two-dimensional (2D) hexagonal structure as well as higher hydrothermal stability. SBA-15 has been synthesized by using amphiphilic triblock-copolymer of poly(ethylene oxide) and poly(propylene oxide) or Pluronic P123 as a surfactant [9].

Such various types of ordered MSMs have been potentially studied for different kinds of applications in catalysts, adsorbents, molecular sieves, drug delivery, sensor, insulating materials and nanometer-scale hosts for optical and electronic materials.

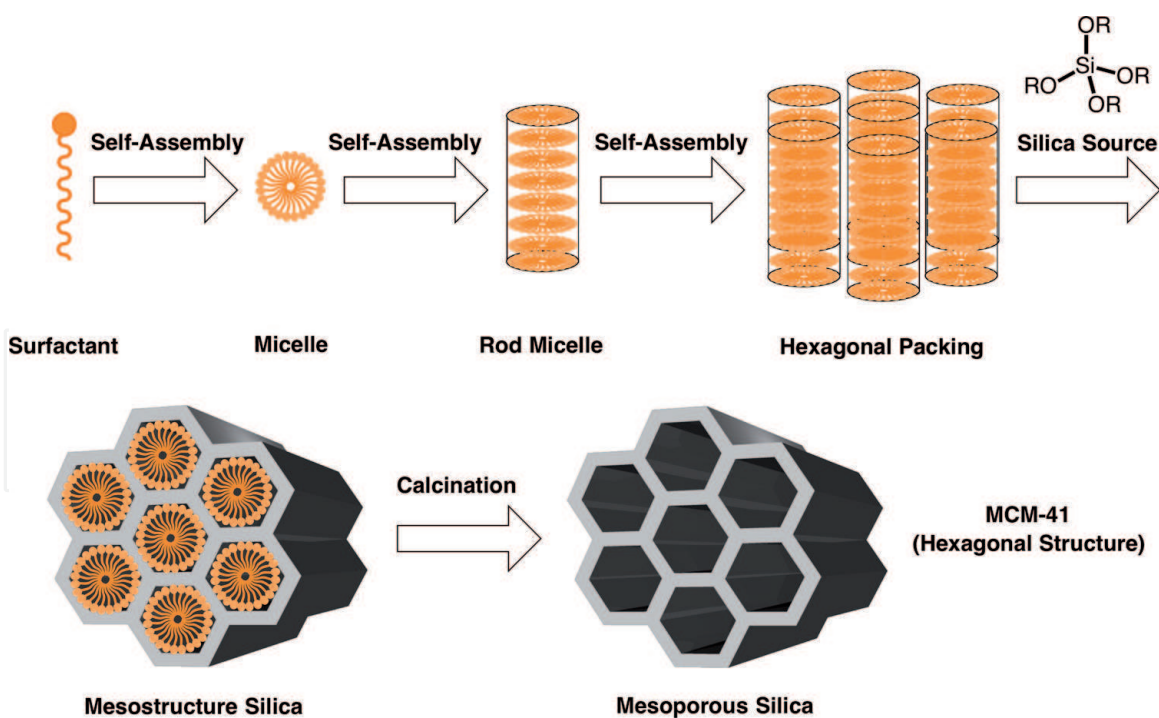

Figure 2. Synthetic scheme for the formation of Mobil Composition of Matters (MCMs)-41 with a hexagonal from calcination of mesostructure silica from sol-gel reaction of self-assembled surfactant in their micelle form with a silica source.

However, the performance of bulk ordered MSMs have been limited in their applications as mentioned in several review journals [10–14]. Hence, ordered MSMs have been functionalized with organic functional groups as multifunctional nanocomposites.

2. Functionalization of mesoporous silica materials

Functionalization of MSMs with organic functional groups became a major topic of research because it can be used for modifying their chemical properties for specific applications at the surface, wall and/or channel at the nanoscale. Moreover, silica frameworks can be designed with specific properties such as hydrophobicity, hydrophilicity, polarity, catalytic active sites, and optical as well as electronic activities so that the performance can be improved in their applications. In this chapter, the functionalization of MSMs will be reviewed using post-synthetic (grafting) and one-pot (co-condensation) methods [15–20] where short discussion will only be provided consisting of the illustration for the formation of mesoporous silica based on the usage of surfactants. At the end of this subheading, these approaches will be then developed as a template sol-gel synthesis for designed multifunctional MSMs where organic chemists can design the desired functions of MSMs for better performance.

2.1 Functionalization with post-synthetic method

Post-synthetic method has been early proposed for functionalization of ordered MSMs by grafting silanol groups consisting of functional organic moieties (F star) at the surface of ordered MSMs. **Figure 3** shows the method where the functional groups in organosilanes can form a covalent bonding with silanol of the MSMs. This method has been firstly introduced from the early discovery of MCM-41 [6] as well as kanemite [3] using trimethylsilyl chloride ($[(\text{CH}_3)_3\text{SiCl}]$) and hexamethyldisiloxane ($[(\text{CH}_3)_3\text{Si})_2\text{O}]$).

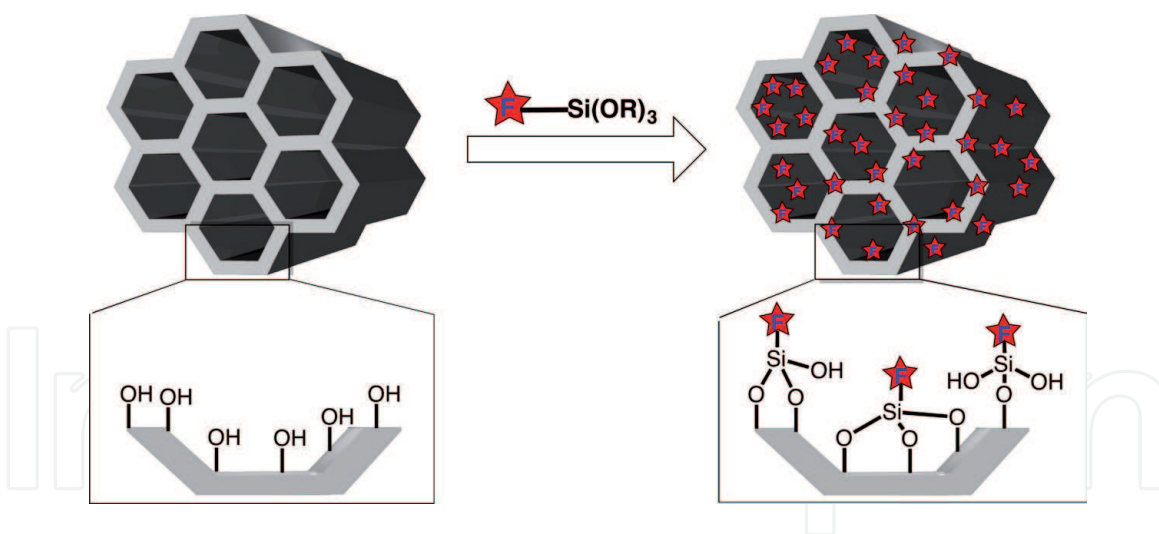

Figure 3.
Post-synthetic method for the functionalization of ordered MSMs.

In the post-synthetic methods, three main approaches have been reported so far using organosilanes and their further modification. Such approaches can be described as follows [17, 21]:

- a. First approach using modification of silica surface with organosilanes such as alkoxysilanes [22, 23], chlorosilanes [6, 24, 25], and silylamines as well as disilazane [26].
- b. Second approach using modifications of previously grafted surface under procedures (a) with other functional groups.
- c. Third approach using transformation of grafted surface under procedures (a) and (b) with additional treatments.

The above approaches can be categorized as grafting with passive (low reactivity) and active (high reactivity) surface groups [16]. However, pore blocking and non-homogenous distribution of organosilanes in the silicate nanochannels are the main problems for the improvement of the properties and performance [19]. Therefore, the functionalized MSMs have been mainly developed for applications in the removal of metal ions and adsorbents [16].

2.2 Functionalization with co-condensation method

As shown in **Figure 4**, co-condensation method has been used for the functionalization of ordered MSMs by mixing organosilanes with silica source and surfactant or structure-directing agent during the sol-gel synthesis. In this method, covalent bonding of a nonhydrolyzable Si—C bond in organosilanes will be hydrolyzed in the sol-gel reaction to form a silica network of mesostructure silica with functional groups in the walls and/or pores [16–19]. Generally, these functional materials have been mainly used for development of optical nanocomposites where specific organic chromophores with such properties can be encapsulated [27].

Two main approaches have been used for co-condensation method based on the types of organosilanes such as mono and bridge silanes attached in the organic functional groups:

2.2.1 Co-condensation method with mono-organosilanes

Co-condensation method with mono-organosilanes has been carried out using mono-functionalization of organosilane as firstly proposed with a simple structure.

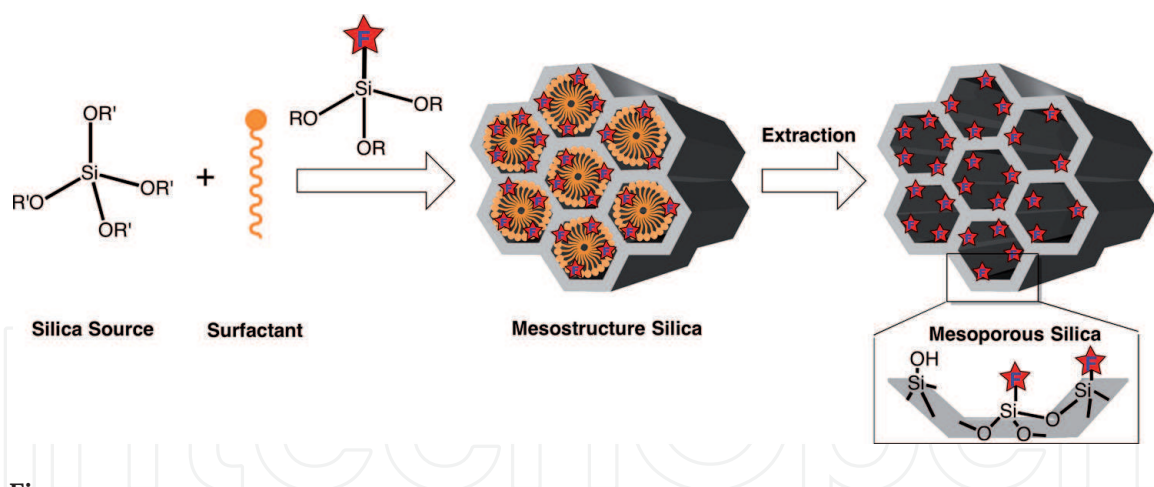

Figure 4.
 Co-condensation method for the organic modification of ordered MSMs with organosilanes.

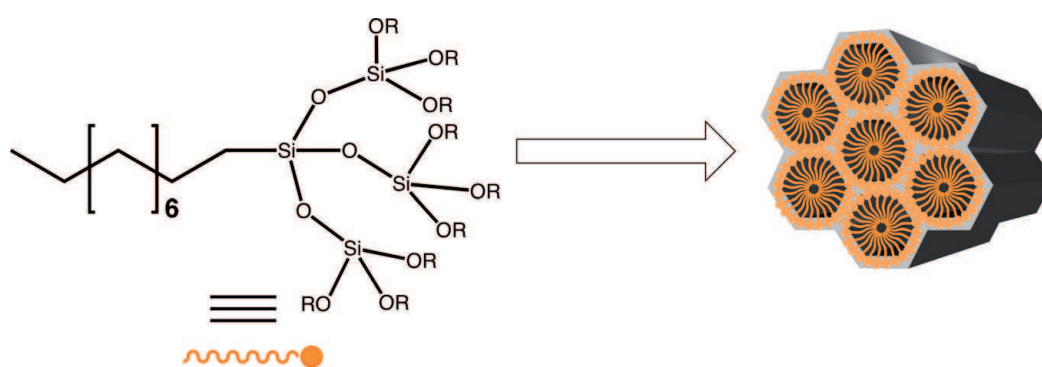

Figure 5.
 Formation of ordered MSMs from siloxane-based dendritic bearing long alkyl chain as a surfactant and a silica source in the sol-gel synthesis of MSMs.

For instance, phenyltriethoxysilane (PTES) or n-octyltriethoxysilane (OTES) [28], 3-aminopropyltrimethoxysilane (APTMS) and 2-cyanoethyltrimethoxysilane (CETMS) [29] and vinyltriethoxysilane (VTES) [30] have been used as mono-organosilanes. However, the main problems in this method have been found such as only 40% of maximum functionalization, reduction in pore diameter and volume as well as decreasing of specific surface area and difficulty in removing of surfactants.

Recently, synthesis of ordered MSMs with mono-organosilanes as both a silica source and a surfactant or structural-directing agent was reported using n-tetradecyldimethyl(3-trimethoxysilylpropyl) ammonium chloride [31]. As shown in **Figure 5**, Shimojima and Kuroda in 2003 [32] have initiated the use of more complicated organosilane structure such as dendritic type of alkoxy-silyl-terminated alkyloligosiloxane [32]. One year later, using dendrimer carbosilanes with its first and second generations, Landskron and Ozin then modified such more complicated structure of the dendritic organosilanes to prepare “Periodic Mesoporous Dendrisilicas” (PMD) as reported in Science 2004 [33]. However, the functional groups attached to the organosilanes in ordered MSM have not yet been applied for specific functions due to its low functionality in the silica framework.

Zhang *et al.* in 2004 [34] was introduced another approach to improve the function of MSMs even the functional surfactant has rigid structure. In this case, they have introduced an amphiphilic alanine-containing alkoxy-silane with a cleavable alkyl chain at the ester group and condensable cationic head-group at siloxane (Lizard template) as shown in **Figure 6**. When they performed acid hydrolysis to the template, it can provide alanine functional groups consisting of cationic ammonium head-group with silanol. Interestingly, alanine functional group in this hybrid material can be used as a heterogeneous catalyst for the acetalization of

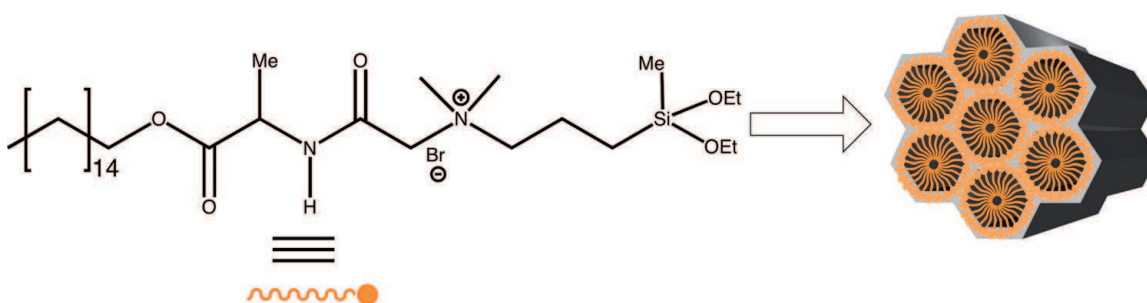

Figure 6.

Formation of ordered MSM from a “lizard” template through sol-gel synthesis and followed by acid hydrolysis.

cyclohexanone in ethanol with high conversion [35]. Such performance was proposed based on the formation of hydrogen bonding from the presence of cyclohexanone and ethanol at the hydrophobic domain at the inner shell and hydrophilic domain at the outer shell with core-shell interface containing amide and carbonyl groups.

2.2.2 Co-condensation method with bridged-organosilanes

Co-condensation method with bridged-organosilanes has been carried out using two trialkoxysilyl groups connected by a functional organic bridge, called as bis-organosilanes to produce “Periodic Mesoporous Organosilicas” (PMOs) as invented independently in 1999 by three research groups [15, 36, 37]. In contrast to above methods, the organic functional groups are incorporated in the three-dimensional network structure of the silica wall through two covalent bonds as shown in **Figure 7**. They are many organic functional groups have been used as bis-organosilanes where the **F** star are methane, ethane, benzene, stilbene, azobenzene, phenyl vinylene, cyclic ethane, dendritic ethane, *etc.* and then used for the synthesis of MSMs with homogeneous distribution of the functional groups in the wall.

Inagaki *et al.* in 2002 [38] reported one of good example in the synthesis of PMO. They have used 1,4-bis(triethoxysilyl)-benzene (BTEB) where the organosilane is based on benzene structure as the functional group. After reaction in a basic condition using sodium hydroxide for 20 hours, the mesostructure silica was successfully synthesized as a white precipitate, and was extracted to remove the surfactant to give plate-like particles of PMO. It shall be noted that PMO has found to form an alternately structure from the layers of hydrophilic silicate and hydrophobic benzene.

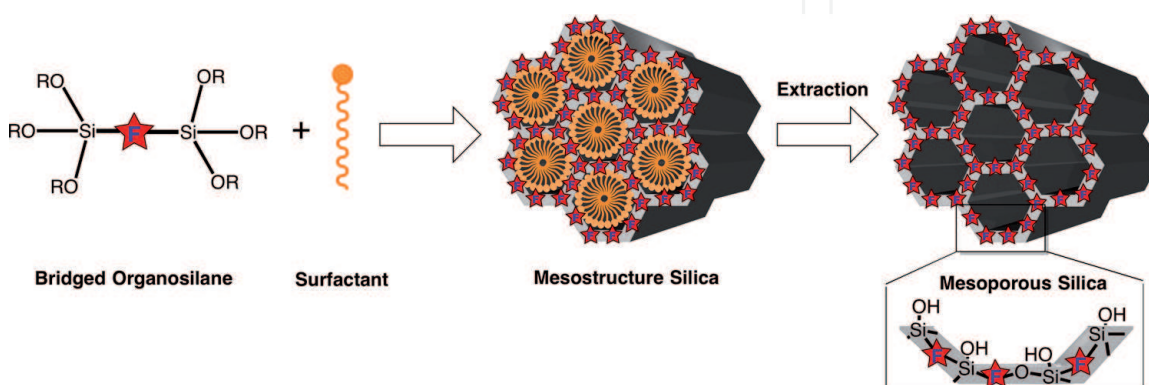

Figure 7.

Co-condensation method for the synthesis of ordered periodic Mesoporous Organosilicas (PMOs) with bridged-organosilanes and surfactant.

2.3 Functionalization with template sol: Gel synthetic method

Since PMOs have been only developed to functionalize the pore wall of MSMs, it is really interesting to guarantee the presence of organic functional groups in the silicate nanochannels. Moreover, the channels of the silicate framework shall be fully occupied by the organic moieties so that they are many functional sites for specific applications. Toward this expectation, it is necessary to design the surfactant containing of functional organic moieties. Therefore, templated sol-gel synthesis method has been proposed using a surfactant in the functionalization of MSMs to form desired multifunctional nanocomposites. This approach has been proposed by using surfactant bearing organic functional groups (called as a “functional surfactant”) as a template in the sol-gel synthesis of ordered MSMs.

Three research groups have firstly proposed in the synthesis of ordered MSM by functional surfactants using amphiphilic diacetylenic monomers [39, 40] and an amphiphilic phthalocyanine [41]). In particular, the functional organic groups will covalently bond in the surfactant molecules where it can be prepared in few step organic reactions. By using this functional surfactant as shown in **Figure 8**, the resulting functional MSMs in the sol-gel synthesis will guarantee dense filling of the silicate nanochannels with the acetylenic functional groups [39, 40]. Therefore, based on the desired functions, the researcher shall decide the organic moieties to be attached covalently and number of functional groups so that the retro-synthesis shall be determined for the synthesis of that surfactants.

In this chapter, the template sol-gel synthesis method will be discussed based on the polymerizable and self-assembled functional surfactants:

2.3.1 Polymerizable surfactant

Polymerizable surfactant as a template in the sol-gel synthesis of ordered MSMs has been independently introduced in 2001 using diacetylene monomers [39, 40]. **Figure 9** shows the example using cationic type of functional surfactants as reported by Aida and Tajima [39]. Polymerization of the resulting mesostructured materials containing dense filling of diacetylenic monomers by photo or thermal treatments gave polydiacetylenes in the nanoscopic channels. In particular, these polydiacetylene nanocomposites have showed photoluminescent hybrid materials with elongated effective conjugation compared to its polymer from monomer directly, indicating the confinement effect in the nanoscale.

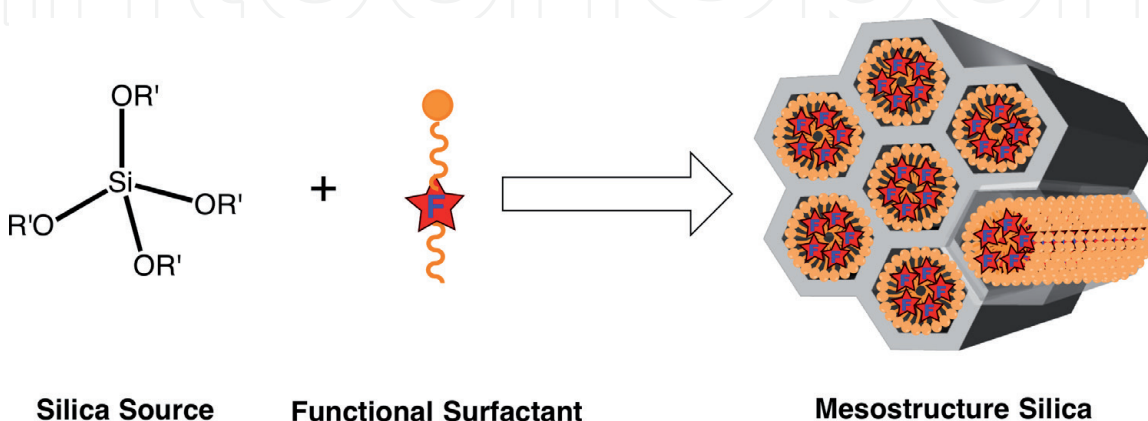

Figure 8.
Co-condensation of ordered MSMs using a surfactant bearing organic functional group as a template for the sol-gel synthesis with silica source.

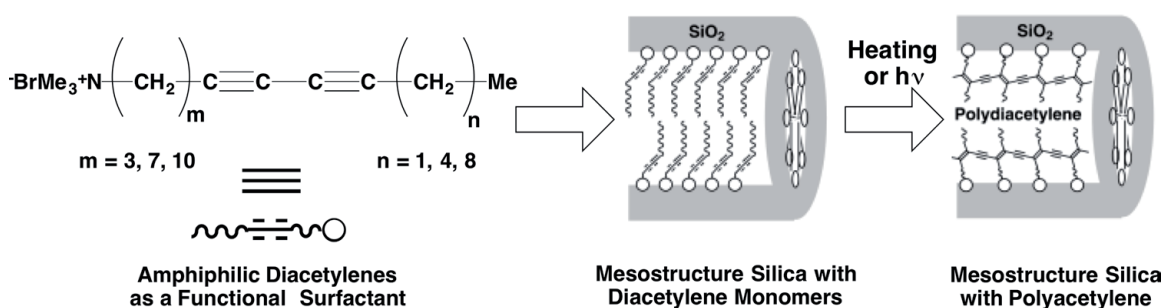

Figure 9. Sol-gel synthesis of ordered MSMs using cationic surfactants bearing organic functional group of diacetylene monomers as a functional template.

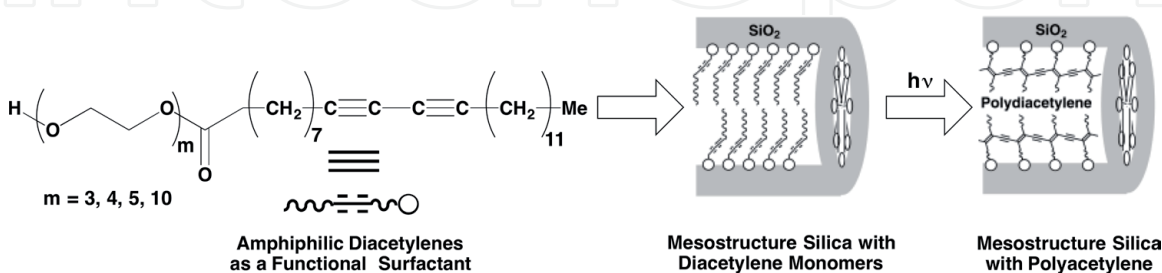

Figure 10. Sol-gel synthesis of ordered MSMs using amphiphilic diacetylenic monomers surfactants as a functional template.

Figure 10 shows the example using amphiphilic type of functional surfactants as reported by Lu *et al.* [40]. Interestingly, they have exhibited chromatic of the blue nanocomposite films to red emission. Such changes have showed not only solvatochromic properties upon exposure to polar solvents to diffuse to hydrophilic ethylene glycol parts, but also thermochromic properties upon heating to form interaction between silanol moieties and alkyl side-chains via hydrogen bonding, as well as mechanochromic properties upon abrasion to form mechanical damage.

In 2003, pyrrole monomers having C10 and C12 alkyl chains were used as a template to synthesize mesoporous silica with both a hexagonal and lamellar geometries. The ordered MSMs with dense filling of pyrrole monomers could be oxidatively polymerized by simply dipping the spin-coated film into initiator FeCl_3 (2 M) in diethyl ether for 1 min [42]. The resulting polypyrrole chains insulated in the hexagonal silicate nanochannels significantly suppressed recombination of polarons into bipolarons, while the lamellar silicate nanochannels afforded spatial freedom for the electron recombination. In the same year, thiophene was used as a template for the polymerization in mesoporous silica to give photoluminescent silica nanocomposite with an alignment of conjugated 100 nm polymer chains in the channels [43].

Other functional polymer nanocomposites have received great attention for the development new materials with good characteristics. To work in this field, redox active functional groups using styrene as a monomer and template was successfully prepared as mesostructured silica/polystyrene nanocomposite film with characteristic of charge transport through a diffusion process [44]. In other reports, luminescent polymers were also successfully prepared using phenylene ethylene [45] and thiophene [46] as a template to give poly(phenylene ethylene) and poly(thiophene) where the nanocomposites showed fluorescent properties with good properties such as higher anisotropic degree and tunable color emission.

2.3.2 Self-assembled surfactant

Self-assembled surfactant as a functional template in the sol-gel synthesis of ordered MSMs has been firstly introduced using an amphiphilic copper phthalocyanine as shown in **Figure 11** [41]. To synthesize the surfactant, the eight decoxy of hydrophobic parts containing triethylene glycol of hydrophilic part was synthesized as amphiphilic side chains in the alkyl bromide. Reaction with copper(I) cyanide through Williamson ether substitution reaction, amphiphilic copper phthalocyanine can be synthesized. This surfactant will form disk-shape (discotic) for self-assembly via noncovalent π - π stacking interactions so that 1D molecular assembly can be insulated within the channels of mesoporous silica.

The columnar assembly in the channels of ordered MSMs can be also synthesized by using charge-transfer interactions of amphiphilic triphenylene as a donor and various acceptors with 1 to 1 mole ratio [47]. In this case, the charge-transfer adduct shall able to form columnar assembly where the donor and acceptor molecules shall be able to be alternated. Without the acceptor molecule, less ordered MSMs have been the amphiphilic triphenylene as a donor molecule prepared. By selecting specific acceptor molecules to be paired, the resulting transparent nanocomposite films can provide color-tunable materials with blue to red with peak top of absorption at 490 nm for 2,4,7-trinitro-9-fluorenone (TNF), 548 nm for 1,2,4,5-tetracyanobenzene (TCNB), 615 nm for 2,3,6,7,10,11-hexacyano-hexaazatriphenylene (HAT), 700 nm for chloranil (CA) and 890 nm for, 7,7,8,8-tetracyanoquinodimethane (TCNQ).

Since less ordered MSMs was found when triphenylene as a donor and functional surfactant was only used in the sol-gel synthesis without the presence of acceptor molecules, the new strategy to synthesize high ordered MSMs is required. By using ethanol vapor in the closed system to the as-synthesized mesostructured silica, the same triphenylene was immersed to ethanol vapor in one drop to give high ordered MSMs in 3 hours at room temperature [48]. The ethanol vapors have a function to increase structure regularity as shown from increasing intensity of the main diffraction peak at d_{100} . Another approach was reported by using the hydrophilic version containing of 18 ethylene glycol side-chains of HBC for the synthesis of nanocomposites [49]. The HBC was firstly prepared using $\text{Pd}(\text{PPh}_3)_4$ in CuI as catalyst for coupling reaction with hexaiodo-*peri*-hexabenzocoronene in the presence of Pd catalyst. Such high hydrophilicity HBC was only produced MSMs with less ordered structure as shown from less intense of the main diffraction peak at d_{100} . Hence, it is really necessary to balance the amphiphilicity from the presence of hydrophobic and hydrophilic side chains of the functional surfactant when there is only one molecule as a template.

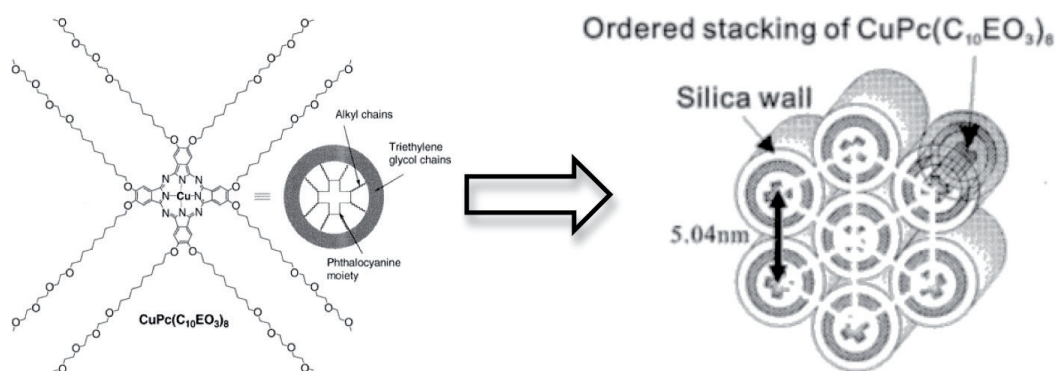

Figure 11. Sol-gel synthesis of ordered MSMs using amphiphilic copper phthalocyanine as a template.

Luminescent nanomaterials with phosphorescent properties have received particular attention for the development of optical materials. To this aim, a weak interaction of metal–metal bonding can be also used to construct columnar assembly with luminescent property. Otani *et al.* [50] was reported that an amphiphilic bispyridine platinum(II) complex, as synthesized from 2,2-bipyridine and K_2PtCl_4 , can be used as a functional surfactant where Pt double-salt from linear chain of Pt-Pt metallophilic interactions between Pt(II) complex with another Pt(II) salt can self-assemble with silica source to form luminescent nanocomposites. Interestingly, these nanocomposites showed phosphorescent properties with an emission peak centered at 619 nm upon an excitation at 495 nm.

Recently, trinuclear gold(I) pyrazolate complex ($[Au_3Pz_3]$) bearing amphiphilic side chains was successfully synthesized to be used as a functional surfactant. This complex showed not only liquid crystalline properties with mesophase range over a wide range of room temperature, but also phosphorescent properties around 700 nm with red emission from Au(I)-Au(I) interactions. Moreover, this surfactant can be utilized as a template for synthesizing transparent mesoporous silica nanocomposite films. The resulting mesoporous silica film ($[Au_3Pz_3]/silica_{hex}$) revealed not only phosphorescent properties of red light at (693 nm with the same excitation wavelength) and longer lifetime (7.8 μs) but also perfect self-repairing with stepwise heating until 140°C in the nanoscale [51]. Such performance can be achieved due to a nanoscopic template effect where the ethylene glycol parts at the side chains anchored in the silica wall play an important role to induce the self-repairing of the pyrazole core on cooling at room temperature thermodynamically. In higher temperature under kinetic control, it is impossible to be achieved due to the strong interaction of the paraffinic side chains. In contrast, such self-repairing in the nanoscale from the light-emitting capability of highly phosphorescent nanocomposites with a hexagonal structure cannot be observed with its lamellar geometry $[Au_3Pz_3]/silica_{lam}$ and bulk Au_3Pz_3 .

In the development of thermally resistive nanomaterials, by using a thin film $[Au_3Pz_3]/silica_{hex}$, the phosphorescent complex in the nanochannels was treated with thermal treatment at the elevated temperature with stepwise or direct heating. Based on the phenomena of thermal quenching, the nanocomposites showed self-repairing capability at room temperature autonomously when was directly heated to 160°C with a heating time in 11 min (luminescent intensity in 59%) compared to stepwise heating in 52 min for every measurement in every 10°C (luminescent intensity in 20%). Such performance can be supported by the presence of endothermic peak as shown from differential scanning calorimetry (DSC) thermogram at 164°C (first heating) or 158°C (second heating). Both peaks can be assigned as a melting temperature from the deformation of metallophilic interaction in the columnar assembly. Hence, self-healing capability in these nanocomposites can be designed based on the heating treatments where perfect autonomously restoration can be achieved with stepwise heating (20–140°C) [51] or direct heating (20–160°C) [52]. Moreover, such capability can be also observed when the stepwise heating was performed until 200°C [53]. All of these phenomena can be monitored by not only the emission changes but also color changes. Hence, this performance can be potentially utilized as temperature sensor with imaging of the changes in intensity and color emission [54]. Such performance cannot be achieved for bulk luminescent compounds or materials with a lamellar structure where thermal quenching can be easily occurred to reduce the light-emitting capability [51–54].

Metal ion sensors have also received deep attention in the research of nanomaterials. In our study, thin film of this phosphorescent mesoporous silica nanocomposite was applied as a chemosensor of silver ions by simply dipping the thin film into the solution of silver triflate (10–100 μM of $AgOTf$). The transparent thin film

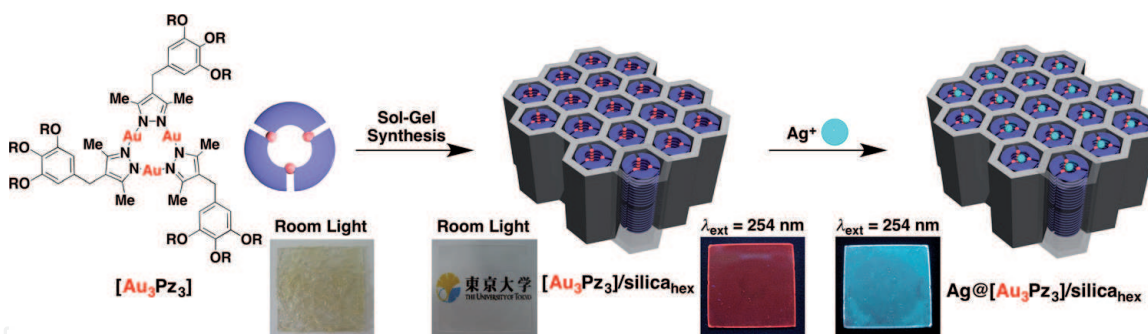

Figure 12. Sol-gel synthesis of ordered MSMs $[Au_3Pz_3]/silica_{hex}$ as a transparent thin film from the pale yellow of sticky amphiphilic trinuclear gold(I) pyrazolate complex $[Au_3Pz_3]$ as a template and then the utilization for the detection of Ag^+ ion to form $Ag@[Au_3Pz_3]/silica_{hex}$.

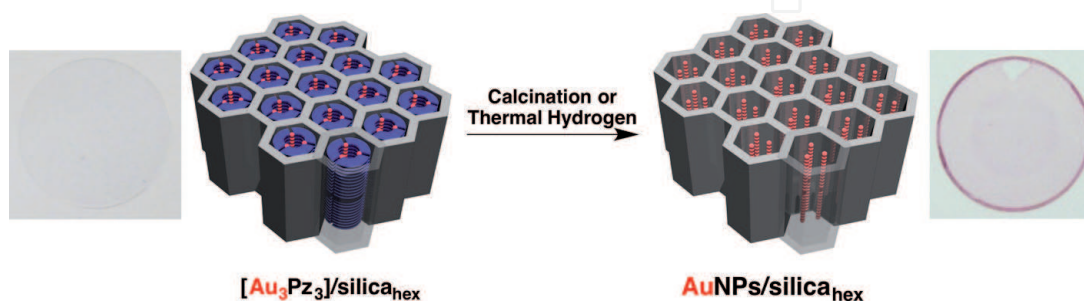

Figure 13. Thermal treatments for the synthesis of AuNPs in the silicate nanochannels.

$[Au_3Pz_3]/silica_{hex}$ with red emission of Au-Au interaction at 693 nm was changed to green (486 nm) of Au-Ag interaction. Moreover, the XPS study with depth profiling indicates that Ag^+ ions were permeated into the silicate nanochannels where the original red emission can be simply recovered in chloroform using cetyltrimethylammonium chloride with the same concentration [55]. **Figure 12** shows the above phenomena from the synthesis of amphiphilic surfactant $[Au_3Pz_3]$ as a template for the sol-gel synthesis of mesoporous silica nanocomposite $[Au_3Pz_3]/silica_{hex}$ as a thin film and then was used for sensing Ag^+ ions with color changes from red to green.

Gold nanoparticles (AuNPs) have also received great attention in many applications. In our research group, the resulting $[Au_3Pz_3]/silica_{hex}$ can be used as a source to form AuNPs in the silicate nanochannels as shown in **Figure 13**. It is important to be noticed that the columnar assembly of $[Au_3Pz_3]$ was fully occupied the silicate channels so that it can provide dense filling of AuNPs in the pore. By using the heat treatment with calcination until 450°C for 3 hours, we have found that the transparent thin film $[Au_3Pz_3]/silica_{hex}$ was changed pink thin film, indicating the formation of AuNP/ $silica_{hex}$. The formation of AuNPs were confirmed by using TEM with the appearance of spherical particles, XRD with the presence of a diffraction peak at 38.2° and UV-Vis spectrometer with the presence of surface plasmon resonance (SPR) peak at 544 nm [56]. Moreover, by using thermal hydrogen treatment at 250°C for hours, it provided the purplish-pink thin film with SPR peak at 558 nm due to the decreasing of particle size [57]. On the other hands, the main diffraction peak at the small-angle area for indicating the hexagonal structure were shifted to higher angle due to the formation of more higher order structure with the same geometry and increasing in pore size. Such template synthesis of nanoparticles can be performed with the confinement effect of gold complexes in the silicate nanochannels. Further research on the detail investigation of the effect on temperature during the heat treatments and applications of AuNPs nanocomposites such as a catalyst will be the interesting reports to be discussed.

3. Conclusions

It can be concluded that ordered MSMs have been organically functionalized with post-synthetic grafting and co-condensation methods with organosilanes. However, these methods gave many limitations in their applications. To solve these issues, new functionalization approach with amphiphilic polymerizable monomer and self-assembled discotic surfactants, called as a functional surfactant, have been used as both a template and an attached-organic functional group based on the desired function in the sol-gel synthesis method. The resulting mesoporous silica nanocomposites in the powder or thin film have gave excellent properties compared to the bulk form. Since noncovalent interactions have received many attentions in the development of soft matters, the utilization of this weak π - π and metal-metal bondings as a discotic surfactant was utilized for templating mesoporous silica nanocomposites. By using phosphorescent metal complex, mesoporous silica/gold complex nanocomposite with a hexagonal structure was successfully fabricated as a thin film with good properties such as self-repairing in the nanoscale, thermally resistive and imaging materials, metal ion sensor, and template synthesis of nanoparticles. Toward these applications, it is possible to use the resulting gold nanoparticles as a heterogeneous catalyst in catalytic reactions. Another outlook of these designed nanocomposites is the potential to engineer the silica wall so that the channel and wall can simultaneously work to give synergistic effect on their applications. Moreover, ordered MSMs with chiral and photochromic columnar assemblies with combination of discotic surfactants and condensable siloxanes will be also interesting perspective for the development of memory nanomaterials.

Acknowledgements

The authors thank Directorate General of Strengthening Research and Development, Ministry of Research, Technology and Higher Education of The Republic of Indonesia for the financial support through Fundamental Research (Penelitian Dasar) Grant. The authors also acknowledge Universitas Ma Chung for the financial support.

Author details

Hendrik O. Lintang^{1,2*} and Leny Yulianti^{1,2}

1 Department of Chemistry, Faculty of Science and Technology, Universitas Ma Chung, Malang, Indonesia

2 Ma Chung Research Center for Photosynthetic Pigments (MRCPP), Universitas Ma Chung, Malang, Indonesia

*Address all correspondence to: hendrik.lintang@machung.ac.id

IntechOpen

© 2019 The Author(s). Licensee IntechOpen. This chapter is distributed under the terms of the Creative Commons Attribution License (<http://creativecommons.org/licenses/by/3.0>), which permits unrestricted use, distribution, and reproduction in any medium, provided the original work is properly cited. 

References

- [1] IUPAC. Manual of symbols and terminology, Appendix 2, Pt. 1. Colloid and surface chemistry. Pure and Applied Chemistry. 1972;**31**:578
- [2] Ishizaki K, Komarneni S, Nanko M, editors. Porous Materials: Process Technology and Applications. 1st ed. Netherlands: Kluwer Academic Publisher; 1998. p. 234
- [3] Yanagisawa T, Shimizu T, Kuroda K, Kato C. The preparation of alkyltrimethylammonium-kanemite complexes and their conversion to mesoporous materials. Bulletin of the Chemical Society of Japan. 1990;**63**: 988-992. DOI: 10.1246/bcsj.63.988
- [4] Inagaki S, Fukushima Y, Kuroda K. Synthesis of highly ordered mesoporous materials from a layered polysilicate. Journal of the Chemical Society, Chemical Communications. 1993:680-682. DOI: 10.1039/C39930000680
- [5] Kresge CT, Leonowicz ME, Roth WJ, Vartuli JC, Beck JS. Ordered mesoporous molecular sieves synthesized by a liquid-crystal template mechanism. Nature. 1992;**359**:710-712. DOI: 10.1038/359710a0
- [6] Beck JS, Vartuli JC, Roth WJ, Leonowicz ME, Kresge CT, Schmitt KD, et al. A new family of mesoporous molecular sieves prepared with liquid crystal templates. Journal of the American Chemical Society. 1992;**114**:10835-10843. DOI: 10.1021/ja00053a020
- [7] Tanev PT, Pinnavaia TJ. A neutral templating route to mesoporous molecular sieves. Science. 1995;**267**:865-867. DOI: 10.1126/science.267.5199.865
- [8] Bagshaw SA, Prouzet E, Pinnavaia TJ. Templating mesoporous molecular sieves by nonionic polyethylene oxide surfactants. Science. 1995;**269**:1242-1244. DOI: 10.1126/science.269.5228.1242
- [9] Zhao D, Feng J, Huo Q, Melosh N, Fredrickson GH, Chmelka BF, et al. Triblock copolymer syntheses of mesoporous silica with periodic 50 to 300 angstrom pores. Science. 1998;**279**:548-552. DOI: 10.1126/science.279.5350.548
- [10] Zhao XS, Max Lu GQ, Millar GJ. Advances in mesoporous molecular sieve MCM-41. Industrial & Engineering Chemistry Research. 1996;**35**:2075-2090. DOI: 10.1021/ie950702a
- [11] Ying JY, Mehnert CP, Wong MS. Synthesis and applications of supramolecular-templated mesoporous materials. Angewandte Chemie International Edition. 1999;**38**:56-77. DOI: 10.1002/(SICI)1521-3773(19990115)38:1/2<56:AID-ANIE56>3.0.CO;2-E
- [12] Scott BJ, Wirnsberger G, Stucky GD. Mesoporous and mesostructured materials for optical applications. Chemistry of Materials. 2001;**13**:3140-3150
- [13] Wan Y, Shi Y, Zhao D. Designed synthesis of mesoporous solids via nonionic-surfactant-templating approach. Chemical Communications. 2009:897-926. DOI: 10.1039/B610570J
- [14] Kresge CT, Roth W. The discovery of mesoporous molecular sieves from the twenty year perspective. Chemical Society Reviews. 2013;**42**:3663-3670. DOI: 10.1039/C3CS60016E
- [15] Asefa T, MacLachlan MJ, Coomb N, Ozin GA. Periodic mesoporous organosilicas with organic groups inside the channel walls. Nature. 1999;**402**:867-871. DOI: 10.1038/47229

- [16] Stein A, Melde BJ, Schroden RC. Hybrid inorganic-organic mesoporous silicates-nanoscope reactors coming of age. *Advanced Materials*. 2000;**12**:1403-1419. DOI: 10.1002/1521-4095(200010)12:19<1403::AID-ADMA1403>3.0.CO;2-X
- [17] Sayari A, Hamoudi S. Periodic mesoporous silica-based organic-inorganic nanocomposite materials. *Chemistry of Materials*. 2001;**13**:1731-1736
- [18] Hatton B, Landskron K, Whitnall W, Perovic D, Ozin GA. Past, present, and future of periodic mesoporous organosilicas—the PMOs. *Accounts of Chemical Research*. 1992;**38**:305-312. DOI: 10.1021/ar040164a
- [19] Hoffmann F, Cornelius M, Morell J, Fröba M. Silica-based mesoporous organic-inorganic hybrid materials. *Angewandte Chemie International Edition*. 2006;**45**:3216-3251. DOI: 10.1002/anie.200503075
- [20] Ariga K, Vinu A, Yamaguchi Y, Ji Q, Hill JP. Nanoarchitectonics for mesoporous materials. *Bulletin of the Chemical Society of Japan*. 2012;**85**:1-32. DOI: 10.1246/bcsj.20110162
- [21] Maschmeyer T. Derivatized mesoporous solids. *Current Opinion in Solid State & Materials Science*. 1998;**3**:71-78. DOI: 10.1016/S1359-0286(98)80068-5
- [22] Sutra P, Brunel D. Preparation of MCM-41 type silica-bound manganese(II) Schiff-base complexes. *Chemical Communications*. 1996:2485-2486. DOI: 10.1039/CC9960002485
- [23] Diaz JF, Balkus KJ Jr, Bedioui F, Kurshev V, Kevan L. Synthesis and characterization of cobalt-complex functionalized MCM-41. *Chemistry of Materials*. 1997;**9**:61-67. DOI: 10.1021/cm960228e
- [24] Chen J, Li Q, Xu R, Xiao F. Distinguishing the silanol groups in the mesoporous molecular sieve MCM-41. *Angewandte Chemie International Edition in English*. 1995;**34**:2694-2696. DOI: 10.1002/anie.199526941
- [25] Zhao XS, Lu GQ. Modification of MCM-41 by surface silylation with trimethylchlorosilane and adsorption study. *The Journal of Physical Chemistry B*. 1998;**102**:1556-1561. DOI: 10.1021/jp972788m
- [26] Anwender R, Nagl I, Widenmeyer M, Engelhardt G, Groeger O, Palm C, et al. Surface characterization and functionalization of MCM-41 silicas via silazane silylation. *The Journal of Physical Chemistry B*. 2000;**104**:3532-3544. DOI: 10.1021/jp993108d
- [27] Nicole L, Boissiere C, Grosso D, Quach A, Sanchez C. Mesostructured hybrid organic-inorganic thin films. *Journal of Materials Chemistry*. 2005;**15**:3598-3627. DOI: 10.1039/B506072A
- [28] Burkett SL, Sims SD, Mann S. Synthesis of hybrid inorganic-organic mesoporous silica by co-condensation of siloxane and organosiloxane precursors. *Chemical Communications*. 1996;**0**:1367-1368. DOI: 10.1039/CC9960001367
- [29] Macquarrie DJ. Direct preparation of organically modified MCM-type materials. Preparation and characterization of aminopropyl-MCM and 2-cyanoethyl-MCM. *Chemical Communications*. 1996;**0**:1961-1962. DOI: 10.1039/CC9960001961
- [30] Lim MH, Blanford CF, Stein A. Synthesis and characterization of a reactive vinyl-functionalized MCM-41: Probing the internal pore structure by a bromination reaction. *Journal of the American Chemical Society*. 1997;**119**:4090-4091. DOI: 10.1021/ja9638824
- [31] Huo Q, Margolese DI, Stucky GD. Surfactant control of phases in the synthesis of mesoporous silica-based

- materials. *Chemistry of Materials*. 1996;**8**:1147-1160. DOI: 10.1021/cm960137h
- [32] Shimojima A, Kuroda K. Direct formation of mesostructured silica-based hybrids from novel siloxane oligomers with long alkyl chains. *Angewandte Chemie International Edition*. 2003;**42**:4057-4060. DOI: 10.1002/anie.200351419
- [33] Landskron K, Ozin GA. Periodic mesoporous dendrisilicas. *Science*. 2004;**306**:1529-1532. DOI: 10.1126/science.1104555
- [34] Zhang Q, Ariga K, Okabe A, Aida T. A condensable amphiphile with a cleavable tail as a “lizard” template for the sol-gel synthesis of functionalized mesoporous silica. *Journal of the American Chemical Society*. 2004;**126**:988-989. DOI: 10.1021/ja039515r
- [35] Otani W, Kinbara K, Zhang Q, Ariga K, Aida T. Catalysis of a peptidic micellar assembly covalently immobilized within mesoporous silica channels: Importance of amphiphilic spatial design. *Chemistry—A European Journal*. 2007;**13**:1731-1736. DOI: 10.1002/chem.200601099
- [36] Inagaki S, Guan S, Fukushima Y, Ohsuna T, Terasaki O. Novel mesoporous materials with a uniform distribution of organic groups and inorganic oxide in their frameworks. *Journal of the American Chemical Society*. 1999;**121**:9611-9614. DOI: 10.1021/ja9916658
- [37] Melde BJ, Holland BT, Blanford CF, Stein A. Mesoporous sieves with unified hybrid inorganic/organic frameworks. *Chemistry of Materials*. 1999;**11**:3302-3308. DOI: 10.1021/cm9903935
- [38] Inagaki S, Guan S, Ohsuna T, Terasaki O. An ordered mesoporous organosilica hybrid material with a crystal-like wall structure. *Nature*. 2002;**416**:304-307. DOI: 10.1038/416304a
- [39] Aida T, Tajima K. Photoluminescent silicate microsticks containing aligned nanodomains of conjugated polymers by sol-gel-based in situ polymerization. *Angewandte Chemie International Edition*. 2001;**40**:3803-3806. DOI: 10.1002/1521-3757(20011015)113:20<3919:AID-ANGE3919>3.0.CO;2-5
- [40] Lu Y, Yang Y, Sellinger A, Lu M, Huang J, Fan H, et al. Self-assembly of mesoscopically ordered chromatic polydiacetylene/silica nanocomposites. *Nature*. 2001;**410**:913-917. DOI: 10.1038/35073544
- [41] Kimura M, Wada K, Ohta K, Hanabusa K, Shirai H, Kobayashi N. Organic-inorganic composites comprised of ordered stacks of amphiphilic molecular disks. *Journal of the American Chemical Society*. 2001;**123**:2438-2439. DOI: 10.1021/ja004034i
- [42] Ikegame M, Tajima K, Aida T. Template synthesis of polypyrrole nanofibers insulated within one-dimensional silicate channels: Hexagonal versus lamellar for recombination of polarons into bipolarons. *Angewandte Chemie International Edition*. 2003;**42**:2154-2157. DOI: 10.1002/anie.200250800
- [43] Li G, Bhosale S, Wang T, Zhang Y, Zhu H, Fuhrhop J-H. Gram-scale synthesis of submicrometer-long polythiophene wires in mesoporous silica matrices. *Angewandte Chemie International Edition*. 2003;**42**:3818-3821. DOI: 10.1002/anie.200351158
- [44] Li G, Bhosale S, Bhosale S, Li F, Zhang Y, Guo R, et al. Template synthesis of functionalized polystyrene in ordered silicate channels. *Chemical Communications*. 2004:1760-1761. DOI: 10.1039/B402794A
- [45] Clark AP-Z, Shen K-F, Rubin YF, Tolbert SH. An amphiphilic poly(phenylene ethynylene) as the

structure-directing agent for periodic nanoscale silica composite materials. *Nano Letters*. 2005;5:1647-1652. DOI: 10.1021/nl050472h

[46] Tu H-L, Tsai F-Y, Mou C-Y. One-step synthesis of ordered mesostructural organic/silica nanocomposites with tunable fluorescence surfactants. *Journal of Materials Chemistry*. 2008;18:1771-1778. DOI: 10.1039/B800070K

[47] Okabe A, Fukushima T, Ariga K, Aida T. Color-tunable transparent mesoporous silica films: Immobilization of one-dimensional columnar charge-transfer assemblies in aligned silicate nanochannels. *Angewandte Chemie International Edition*. 2002;41:3414-3417. DOI: 10.1002/1521-3773(20020916)41:18<3414:AID-ANIE3414>3.0.CO;2-T

[48] Okabe A, Niki M, Fukushima T, Ariga K, Aida T. Ethanol vapor-mediated maturing for the enhancement of structural regularity of hexagonal mesoporous silica films. *Chemical Communications*. 2004:2572-2573. DOI: 10.1039/B410095F

[49] Wu J, Li J, Kolb U, Mullen K. A water-soluble hexa-*peri*-hexabenzocoronene: Synthesis, self-assembly and role as template for porous silica with aligned nanochannels. *Chemical Communications*. 2006:48-50. DOI: 10.1039/B511868A

[50] Otani W, Kinbara K, Aida T. Template sol-gel synthesis of mesostructured silica composites using metal complexes bearing amphiphilic side chains: Immobilization of a polymeric Pt complex formed by a metallophilic interaction. *Faraday Discussions*. 2009;143:335-343. DOI: 10.1039/b904896k

[51] Lintang HO, Kinbara K, Tanaka K, Yamashita T, Aida T. Self-repair of a one-dimensional molecular assembly in mesoporous silica by a nanoscopic

template effect. *Angewandte Chemie International Edition*. 2010;49:42411-44245. DOI: 10.1002/anie.200906578

[52] Lintang HO, Kinbara K, Yamashita T, Aida T. Heating effect of a one-dimensional molecular assembly on self-repairing capability in the nanoscopic channels of mesoporous silica. In: *Proceedings of International Conferences on Enabling Science and Nanotechnology (ESciNano)*. Vol. 2010. Kuala Lumpur, Malaysia: IEEE; 2010. p. 5700970. DOI: 10.1109/ESCINANO.2010.5700970

[53] Lintang HO, Kinbara K, Aida T. Thermally resistive phosphorescent molecular assembly in the channels of mesoporous silica nanocomposites. In: *Proceedings of International Conferences on Enabling Science and Nanotechnology (ESciNano)*. Vol. 2012. Johor Bahru, Malaysia: IEEE; 2012. p. 6149684. DOI: 10.1109/ESciNano.2012.6149684

[54] Lintang HO, Yuliati L, Endud S. Phosphorescent sensing and imaging of temperature using mesoporous silica/gold nanocomposites. *Materials Research Innovations*. 2014;18:S6 444-S6 448. DOI: 10.1179/1432891714Z.00000000995

[55] Lintang HO, Kinbara K, Yamashita T, Aida T. Metal-ion permeation in congested nanochannels: The exposure effect of Ag⁺ ions on the phosphorescent properties of a gold(I)-pyrazolate complex that is confined in the nanoscopic channels of mesoporous silica. *Chemistry--An Asian Journal*. 2012;7:2068-2072. DOI: 10.1002/asia.201200041

[56] Jalani MA, Yuliati L, Lintang HO. Thermal hydrogen reduction for synthesis of gold nanoparticles in the nanochannels of mesoporous silica composite. *Jurnal Teknologi*. 2014;70:131-136. DOI: 10.11113/jt.v70.3420

[57] Jalani MA, Yuliati L, Endud S, Lintang HO. Synthesis of mesoporous silica nanocomposites for preparation of gold nanoparticles. *Advanced Materials Research*. 2014;**925**:233-237. DOI: 10.4028/www.scientific.net/AMR.925.233

IntechOpen

IntechOpen